

PVA Polarizers Laminated with PET

A. Geivandov, P. Lazarev

Crysoptix KK, Level 27, Shiroyama Trust Tower, 4-3-1 Toranomom, Minato-ku, Tokyo, Japan

ABSTRACT

Conventional PET film (+A plate) when coated with Crysoptix Thin Birefringent Film TBF™ retarder can efficiently replace TAC substrate in LCD polarizer. New polarizer design for VA LCD and IPS LCD provides over 3 B USD cost reduction and improves durability.

1. INTRODUCTION

Upstream component cost reduction is a major trend in the LCD industry because the components account for 70-85% in the cost structure of TFT LCD. Polarizer is the key LCD component. Crysoptix KK has developed a cost effective technology for manufacturing thin birefringent films (TBF™) by coating technology [1-3]. The TBF™ is a submicron film produced from a solution of organic material by coating onto a plastic (with roll-to-roll slot-die) or glass (with flat-bed slot-die) substrate.

Contemporary LCD polarizer comprises PVA film laminated between TAC films [4] which function as a low-retardation negative C-plate exhibiting birefringence $\Delta n = 0.001$. TAC film has preferable optical properties, such as low haze, birefringence and depolarization index, however it has poor mechanical properties in comparison to alternative polymer films, such as Polyethylene Terephthalate or PET (see Table 1).

Table 1. Comparison of TAC and PET films

Property	Unit	TAC	PET
Thickness	μm	100	100
Density	g/cm ³	1.3	1.4
Rupture strength	MPa	118	230
Rupture elongation	%	30	120
Water vapor transmission rate	g/m ² /24hr	700	21
Oxygen transmission rate	cc/m ² /hr/atm	110	3
Water absorbency	%	4.4	0.4
Breakdown voltage	KV	3	6.5
Volume resistivity	Ω·cm	1015	1017
Dielectric constant	-	3.5	3.2
Dielectric tangent	-	0.02	0.002
Melting point	°C	290	258
Operation temperature	°C	to 120	-70 to 150
Organic solvent tolerance	-	poor	Good
Acid tolerance	-	poor	Good
Alkali tolerance	-	poor	Moderate

PET possesses much better mechanical properties than TAC - thus substantially thinner film of PET can efficiently replace TAC film. PET is also several times less expensive than TAC. However PET film functions as a positive A-plate exhibiting high birefringence of $\Delta n=0.01-0.05$. These optical properties are not suitable for current LCD manufacturing technology.

In this paper we propose an original approach which allows using PET and other birefringent plastic films with superior mechanical properties as a substrate for LCD polarizer in LCD manufacturing. High birefringence of such films can be compensated with Crysoptix coatable retarders.

2. LCD DESIGNS

2.1 Compensation of VA LCD

Let's consider optical compensation of VA LCD design.

In conventional VA LCD the LC cell of retardation $R \sim 275-300$ nm is placed between two polarizers and compensated by positive A-plate having $R \sim -69$ nm, $R_o \sim 138$ nm laminated to front polarizer and negative C-plate of $R = -220$ nm [5].

VA LCD mode can be compensated with a PET substrate film functioning as a positive A-plate and only one negative C- plate retarder.

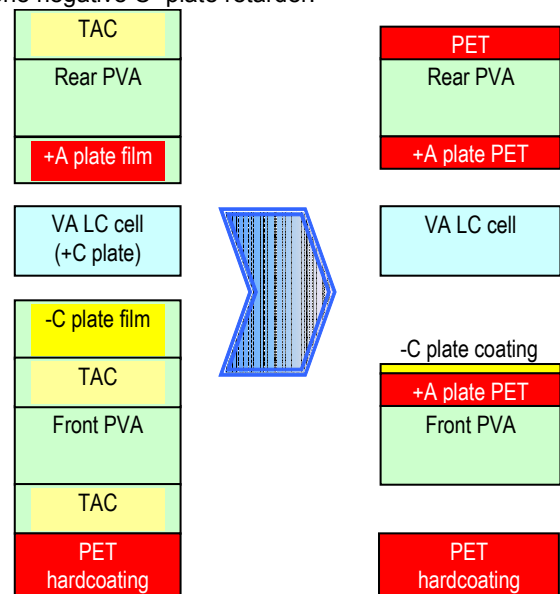

Fig. 1. VA LCD design: old vs new. Optical axis of positive A-plates coincides with transmission axes of the polarizers

Due to high durability a PET substrate for LCD polarizer can be substantially thinner than TAC substrate. It makes a new non-TAC polarizer substantially thinner as well. Furthermore a hard coating PET film protecting a front polarizer can be used as a polarizer substrate: one film less.

We simulated viewing angle characteristics of one of possible new VA LCD designs using LCD TDK simulation software by Dr. S. Palto with algorithm described in [6].

The following parameters were used for simulation:

- PET film with function of positive A-plate of $\Delta n=0.01$

- and thickness of 11 μm ,
- Crysoptix negative C-plate TBFTM retarder of $\Delta n=0.12$ and thickness of 1.2 μm .

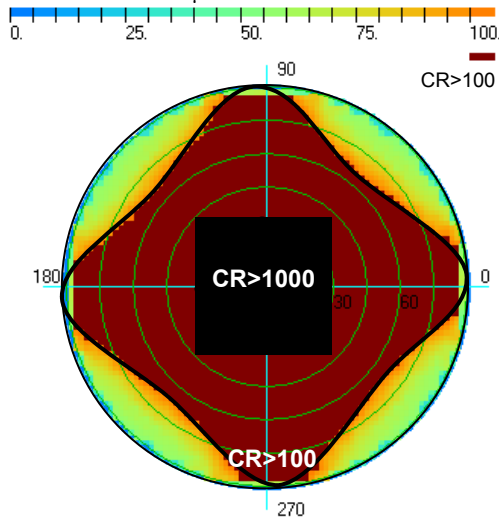

Fig. 2 Viewing angle performance (simulation) of compensated multidomain VA LCD

2.2 Compensation of IPS LCD

In traditional IPS LCD the LC cell of $R \sim 275 \text{ nm}$ is placed between two polarizers and compensated with negative A-plate having $R \sim -150 \text{ nm}$ laminated to one of the zero-retardation TAC polarizers. If conventional TAC film is used as a polarizer substrate, an additional positive C-plate is required to compensate negative C-plate retardation of TAC.

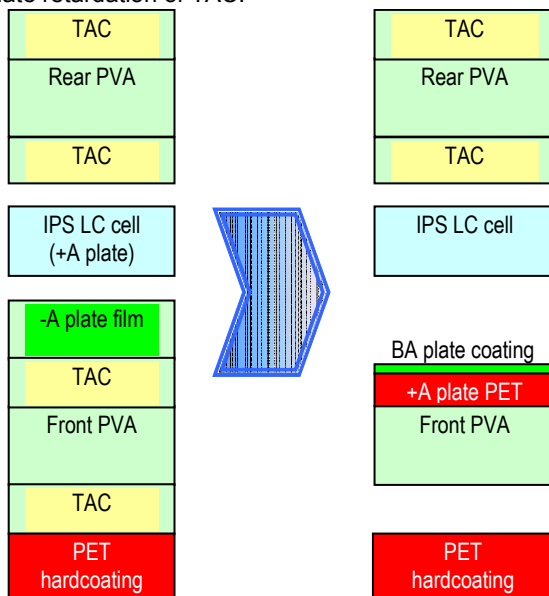

Fig. 3. IPS LCD design: old vs new

We simulated viewing angles characteristics of one of feasible IPS LCD designs.

The following parameters were used for simulation:

- PET film (positive A-plate) of $\Delta n=0.01$ and thickness of 11 μm , placed between polarizers, ,
- TAC film (negative C-plate) of $\Delta n=0.001$ and thickness of 40 μm , placed between polarizers, ,
- Crysoptix biaxial B_A-plate TBFTM retarder with principal refractive indices $n_x=1.6$, $n_y=1.8$, $n_z=1.7$, and

thickness of 0.3 μm . The principal axis of the largest in-plane refractive index n_y coincides with the transmission axis of the front polarizer.

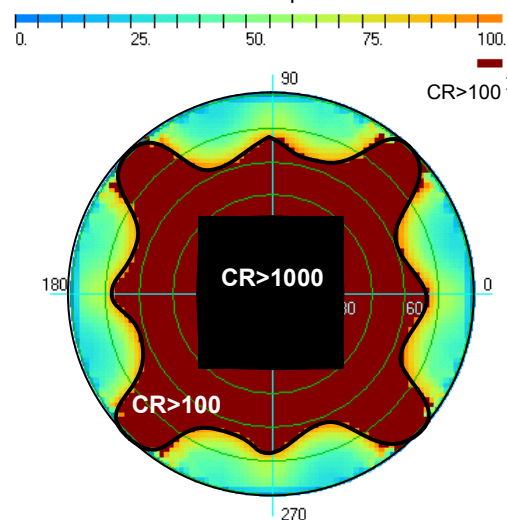

Fig. 4. Viewing angle performance (simulation) of compensated IPS LCD

2.3 Discussion

Coatable TBFTM retarder technology enables cost efficient optical compensation of polarizer substrate of any birefringence. Thus, redundant retardation of substrate can be offset by appropriate birefringent coating, and it allows using a plastic substrate of choice for manufacturing a superior product.

3. CONCLUSIONS

Application of non-TAC LCD polarizer provides a significant cost reduction, and this design is enabled by using a thin coatable retarder for compensation of uniaxial in-plane birefringence of inexpensive plastic substrate, like PET.

The coatable retarder approach enables new optical designs, wherein any redundant birefringence of optical elements can be compensated by one or few birefringent coatings.

This approach allows using PET as a substrate for all optical films in LCD stack.

5. REFERENCES

- [1] www.crysoptix.com
- [2] PCT publications: WO2007080419; WO2007080420; WO2007042788; WO2007141025, WO2008020211, WO2008020213, WO2008084109, and WO2008142635.
- [3] A. Lazarev et al., "Single-layer retarder for LCD", Proc. IDW'08, pp. 1741-1744 (2008).
- [4] P. Yeh and C. Gu, Optics of Liquid Crystal Displays, (Wiley, New York, 1999).
- [5] A. Uchiyama et al., "Novel Design Method Using Birefringence Dispersion Control of Retardation Films for High Contrast LCD in Wide Viewing Angle Range", Proc. IDW'04, pp. 647-650 (2004).
- [6] S.P. Palto "An algorithm for solving the optical problem for stratified anisotropic media", JETP, v. 92, No.4, pp.552-560 (2001)